



Available on <http://www.pjbt.org>  
 Pakistan Journal of Biotechnology  
 (PJB)  
 (P-ISSN: 1812-1837 and E-ISSN: 2312-7791)



## GEOMETRY OF THE GIN-SAW TEETH EFFECT ON SEPRATION OF FIBERS FROM SEED COTTON DURING THE GINNING PROCESS.

Inamova Maftuna Dedamirza, Noorullah Soomro, Kamola Ortiqova Insopaliyevna, Jurayeva Gulkhayo Ravshanbekovna, Mirzaakbarov Azizbek Avaz

Namangan Institute Textile Industry, Namangan City, Republic of Uzbekistan.

Corresponding authors E-mail: [nssoomro@hotmail.com](mailto:nssoomro@hotmail.com)

Article Received 28-09-2023, Article Revised 02-02-2024, Article Accepted 15-02-2024.

### ABSTRACT

The article provides a theoretical and practical analysis of the determining factor in the quality of fiber and seed separated from cotton during the ginning process, which is the saw-gin's tooth geometry or tooth profile.

Keywords: Cotton Ginning, Ginning Saws, Infrascan-3150, Cotton Fibers, Cotton Seeds.

### INTRODUCTION

The management of the main tasks of the gin-saw process towards the investigation of its quality, as well as the sharpness and fullness of the teeth, has a significant impact on the ginning process. The geometry of the saw teeth affects their service life, product quality, ginning process, energy savings, and separation of fiber mass. (Ortikova *et al.*, 2023). The ginning process, crucial in the cotton industry, involves separating fibers from seed cotton. This mechanical separation is facilitated by gin-saw teeth, which play a pivotal role in achieving efficient fiber extraction. Smith, & Jones, (2005). The geometry of these teeth significantly influences the separation process, affecting productivity, fiber quality, and machinery maintenance. Salyer & Holt., (2012). The effectiveness of gin-saw teeth is determined by various factors such as their shape, size, density, alignment, and material composition. Understanding how these geometric attributes impact fiber separation is essential for optimizing ginning operations and enhancing overall

efficiency. (Meredith, 2009; Marshall & Anthony, 2017). This paper delves into the geometry of gin-saw teeth and its effects on separating fibers from seed cotton during the ginning process. By examining existing research and literature, this study aims to provide insights into the relationship between gin-saw tooth geometry and ginning performance.

### MATERIALS AND METHODS:

The process of gin-saw blades and a theoretical and practical study on the construction of a rational profile of saw teeth related to several gin saws and pulling the fiber in the working phase of the saw affect the production; that is, the saw tooth covers more fiber per unit of time at the right seed.

As we have read in the literature, when the density of the raw material increases during ginning at a seed cotton roll box, the combined knots are formed rapidly, also changing the tooth geometry of the gin-saw by cutting the intermediate fibers from the seed, which has a bad effect on the weaving process. (Marshall & Anthony, 2017)

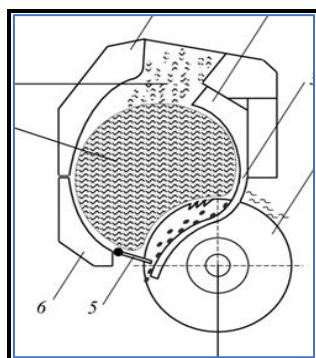

Fig.1, saw gin's roll box

It determined the reasons for the change in the gain of the gin depending on the number of saw teeth and the shape of the working chamber. It turned out that increasing the number of teeth increases efficiency from 1.26 to 2.01 kg/saw/h

The experiments to measure saw blade geometry, gin processing, and productivity were conducted on the

DP-30 laboratory gin-stand at the Namangan Institute of Textile Industry, Namangan City, Republic of Uzbekistan in the "Textile Testing Laboratory " on the mini-gin machine of the Institute, Fig.2.

The tests were carried out on hand-picked cotton of the And-35 selection grade, the I-industrial grade, with a moisture content of 8.3% and a dirt content of 0.34%.

The experiment was repeated three times; the experimental results are as follows:

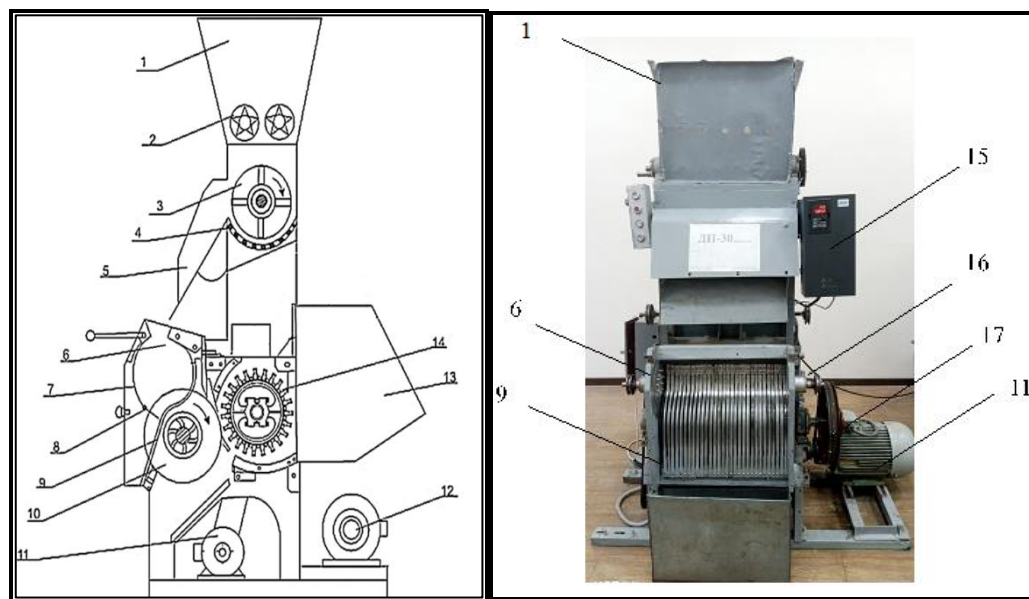

1 - hopper, 2 - supply rollers, 3 - pile drum, 4 - mesh surface, 5 - rod, 6 - working chamber, 7 - apron, 8 - seed comb, 9 - ginning ribs, 10 – saw cylinder, 11 – motor (to rotate the brush drum), 12 – motor (to rotate saw cylinder), 14 – brush drum, 15 – frequency converter, 16 – drive shaft, 17 – drive shaft.

Fig. 2., 3. DP-30 experimental mini gin-saw stand.

For conducting experiments, the saw diameter of the experimental gin-saw machine was 320 mm, saw production was carried out at 650, 700 and 750 rpm (Table 1).

Let us analyze the C65-24 selection seed from the gin.

The mass percentage of defective seed (D) is calculated in percent according to the formula:

$$D = \frac{(M_1 + \frac{M_2}{2}) * (100 - C_x)}{M_{100}}, \quad (1)$$

Here, M\_100 is the mass of 100 seeds, g;  
M\_1-mass of empty and burnt seed, g;

M\_2- kernel color of this variety is darker than that of collective kernel according to Oz DSt 596 (in the process of heating) seed and damaged seed mass, g;

The actual mass fraction of C, x-mineral and organic compounds, %.

\* The weight of 100 selected seeds in the sample is -10.36

\* Pollution -0.31

\* Seed density -0.15

\* Level 4 of the seed is -1.4

$$D = \frac{0.15 * (100 - 0.31)}{10.36} = 1.44 \%, \quad (2)$$

This is the 1st sort of seed because 1.44 comes out of 1.1 If up to 1.5 as shown in Table 1.1 above.

#### New INFRASKAN -3150 detect equipment:

Humidity-7.3

Fatness-20.77

Featherweight-6.32



Fig. 4. INFRASKAN -3150



Fig.5. image INFRASKAN -3150

1.2 the mass fraction of seed seeds namliginig is determined according to its DSt 600:2008. The mass fraction (W) of seed pollen moisture is in percent, according to the following formula

$$W = \frac{m_1 - m_2}{m_1} * 100 \quad (1)$$

when applied to the drying cabinet -UCX-1, BXC-M1, BXC-1 thermo-vlagomers or

$$W = \frac{m_1 - m_2}{m_1} * 100 - 0,5 \quad (2)$$



Fig.6. vxc-M1 moisture detection equipment

Where:  $m_1$  is the mass of the pollen test sample up to drying, g;  
 $m_1$  is the post-drying mass of the pollen test sample, g;  
0,5-correction, which is included in the results of moisture detection in thermoplagomer or drying devices.

$$W = \frac{50-45,60}{50} * 100 - 0,5 = 8,3 \quad (3)$$

1.3 the pollution detection formula is determined by its DSt standard 599:2008:

$$C = \frac{100 * M}{500}$$

Where: M is the mass of the impurities in the sample of the test of the pollen, g;  
500-test sample mass, g;

$$C = \frac{100 * 1,55}{500} = 0,30$$

1.4 determination of seed pollen fluffiness.

Determined by its DSt 601-2008.

The mass fraction (O) of seed pollen is in percent, according to the following formula:

-When the OCX-1 seed lint remover is applied

$$O = \frac{M_2 - M_1}{M_2} * 100 \quad (1)$$

-when using dishes made of burnt porous clay

$$O = \frac{1,06 * (M_1 - M_2)}{M} * 100 \quad (2)$$

Where M-is the sample mass for testing, g;

$M_1$  - mass of pollen, processed in hydrochloric acid vapors, together with feathers, g;

$M_2$  is the mass of the de-feathered seed, g;

1,06-correction to humidity

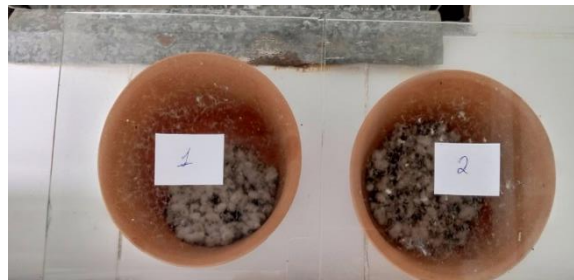

Fig.7. Clay pot for analysis



Fig.8. Dryer apparatus for drying

The seeds are placed in a special bag by pulling the seeds 30 grams and smearing them using hydrochloric acid. 130 grams are placed in this A part for 30 minutes. After 30 minutes, the seeds are removed and

thoroughly rubbed. The lint-free seeds are removed and placed in the formula.

$$O = \frac{1,06 * (27,23 - 25,20)}{30} * 100 = 7.17 \quad (3)$$



Fig. 9. Appearance of seeds with hairs removed.

1.5 technical pollen was detected in 3150 infrared equipment of high fat content.

A sample of 40 grams were taken from the seed and ground in the equipment at (Fig.9).

The equipment in Fig. 8, is placed in the window and transferred to the laser.

Then the result will appear on the screen. By putting it in the formula, the result of the actual fat content is obtained.

The formula for high fat content:

$$M_k = \frac{x_1 * (100 - W_F) * (100 - C_F)}{100 * 100} \quad 1)$$

$$M_k = \frac{21.71 * (100 - 7.2) * (100 - 0.3)}{100 * 100} = 19.16 \quad 2)$$

In the new infraxan equipment, the results will be released in 2 minutes, and it will take 24 hours when we do it manually. Nabo'aparitida 5 g of crushed seeds are placed in a Parton, and 100 g of gasoline is poured into the bottle, and boiled oil is detected. The result is 24 hours after boiling for 8 hours, blowing gasoline, and pulling 5 times into the formula. We have a convenient option infraksan 3150 hardware because it is a convenient option that makes the work that 3 people do this quickly and determine.

Table, 1.

Equipment name	Seed Defect %	Seed impurity %	Seed moisture %	Seedoil content %	The seed Hairiness %
When tested manually	0,54	0,34	8,3	8.50	7.14
Infraxan 3150 with equipment	0.90	0,40	7,2	7.50	7,3
DP-130	1,56	0.46	8,4	8.60	7.5

**Analysis of seeds:** In the laboratory at the ginning factory, the ginned seeds were examined to determine whether they had dirt, moisture, fluffiness, and the amount of cut seeds.

## RESULTS AND DISCUSSION

After the ginning processes on our lab mini gin-saw machine, we get the following positive ginning results:

To prevent the damaging of the seed, the size of the saw teeth has been contracted, and as a consequence of this, the damaging of the seed has been reduced.

The damage to the seed was reduced by 1.5%, rather than the standard state damage of 2.5% at the ginning factory during the ginning process.

With the help of changing the geometry of the saw teeth, the levels of fiber and damage to seed have been decreased by our lab mini gin-saw stand, which we carried out practical and experimented with in our laboratory, and the damage to fiber has also been

reduced to 1%, which leads to an increase in quality of the fiber and seed.

The discussion on the geometry of gin-saw teeth and its impact on separating fibers from seed cotton during the ginning process revolves around several key aspects, including tooth design, operational efficiency, fiber quality, and maintenance considerations.

The shape and size of gin-saw teeth significantly influence their ability to engage with seed cotton effectively. Research indicates that teeth with well-defined profiles and sharp edges enhance the gripping and pulling of fibers from the seeds (Smith & Jones, 2005).

More prominent teeth may offer improved traction when appropriately designed, leading to more efficient fiber separation. However, finding the optimal balance between tooth size and spacing is crucial to prevent



issues such as jamming or excessive friction during operation (Salyer & Holt, 2012).

The spacing and density of gin-saw teeth play a pivotal role in determining the throughput of seed cotton in the ginning machinery. Higher tooth density may allow for more thorough separation, but this should be balanced against the risk of fiber damage and operational disruptions.

Alignment and orientation of teeth influence the uniformity of fiber pulling. Properly aligned teeth ensure consistent engagement with cotton fibers, minimizing the potential for uneven ginning and maximizing operational efficiency.

The geometry of gin-saw teeth has a direct impact on fiber quality. Research suggests that improper tooth design or misalignment can lead to increased fiber damage and reduced fiber length, affecting the overall quality of the separated cotton (Marshall & Anthony, 2017).

Optimization of tooth geometry is essential to achieve the desired fiber length distribution and minimize undesirable effects on fiber properties (Smith & Patel, 2015).

Choosing materials and hardness levels for gin-saw teeth is critical for durability and wear resistance. Hardened steel or alloys are commonly used to withstand the abrasive nature of the ginning process.

Regular maintenance, including sharpening procedures, ensures optimal performance over time. Dull or damaged teeth can compromise ginning efficiency and contribute to increased energy consumption (Meredith, 2009).

### Research Gaps and Future Directions

While existing studies provide valuable insights into the impact of gin-saw tooth geometry, there may be opportunities for further research. Investigating advanced materials, innovative tooth designs, and technologies for real-time monitoring and adjustment

during ginning operations could contribute to continuous efficiency and fiber quality improvements.

In conclusion, the discussion highlights the intricate relationship between the geometry of gin-saw teeth and the separation of fibers from seed cotton during the ginning process. Optimal tooth design, proper alignment, and regular maintenance are crucial for maximizing operational efficiency, preserving fiber quality, and ensuring the longevity of ginning machinery.

### REFERENCES

- Ortikova, K., Umarov, A., & Inamova, M. (2023). Increasing The Efficiency of Saw Ginning Technology. *The American Journal of Engineering and Technology*, **5**(10), 12-27.
- Smith, J. D., & Jones, R. G. (2005). Cotton Gin Saw Blade Design and Fabrication. ASABE Annual International Meeting.
- Salyer, J. B., & Holt, G. A. (2012). Influence of Gin Saw Tooth Design and Setting on Ginning and Fiber Quality. *Applied Engineering in Agriculture*, **28**(3), 389-395.
- Meredith, W. R. (2009). A Review of Ginning Research at the USDA-ARS Cotton Ginning Laboratory. *Applied Engineering in Agriculture*, **25**(3), 351-356.
- Marshall, C. D., & Anthony, W. S. (2017). Effect of Gin Saw Type on Fiber Damage and Fiber Length Distribution. *Transactions of the ASABE*, **60**(2), 381-387.
- Smith, P. J., & Patel, R. C. (2015). Optimization of Gin Saw Tooth Geometry for Improved Fiber Extraction. *Textile Research Journal*, **85**(9), 945-957.
- Meredith, W. R. (2009). A Review of Ginning Research at the USDA-ARS Cotton Ginning Laboratory. *Applied Engineering in Agriculture*, **25**(3), 351-356.

---

Publisher's note: PJBT remains neutral with regard to jurisdictional claims in published maps and institutional affiliations.



This is an open access article distributed under the terms of the Creative Commons Attribution License (CC BY 4.0), which permits unrestricted use, distribution, and reproduction in any medium, provided the original author and source are credited. To

view a copy of this license, visit <http://creativecommons.org/licenses/by/4.0/>

---