

ANALYSIS OF HYBRID FULL ADDER TOPOLOGIES BASED ON IMPROVED DRPTL

Shibi O. and P. Manimegalai

Karagam University, Coimbatore, Tamil Nadu, India. shibi.jayt@gmail.com

ABSTRACT

Recently adder circuit is becoming a major part in many applications and the arithmetic circuit is included in it as a fundamental operation. Basically the adder circuit is designed to achieve low power and less delay and by logic gate of the circuit improves the performances. In this paper, for significant process of power saving and efficient performances Hybrid Full Adder Topologies is proposed dynamically based on dual rails pass transistor logic (DRPTL) with the clock signal. For speed process high logic circuit is implemented and also to have less propagation. In hybrid CMOS design style various adder cells and transistor is used, but in proposed circuit DRPTL is implemented with the load condition and the clock signal to manage the power flow in the circuit. Also enhance the device performances and reduce the chip level power consumption. The proposed circuit is simulated for the analysis of performances by the implementation in Cadence Virtuoso Schematics on 45nm CMOS process models and illustrated the results performances delay, power, and transistor count reduction.

Keywords: Full Adder; Pass Transistor; Hybrid; SRPTL;

1. INTRODUCTION

In well-engineered deep submicron CMOS technologies, the difficult criteria are concentrating on emerging communication process high speed with low power in digital signal processing chip. Nowadays, the complex criteria of emerging high-speed communication process are increased in CMOS technologies used applications. Based on the logic circuit the complex process is performed the arithmetic division of adder circuit with multiplier in VLSI system. However, the growth of electronics is increased with the critic fear of reduction in delay, power and area in any application. In this the high demand and growth are reliabilities, high speed, convenient electro-nic product, area and battery lives. In various logic circuits and algorithm like parity checker, converter of code, compressors and error correcting code or detector are basically used the building blocks of XOR-XNOR circuit.

For better performances and improvement, the design chip is scale down the device size of portable device and led the consumption of power system to increase the chip density and the complexity. So, the cooling of portable devices required expensive device and it will affect the life of the battery. Also, it's specified as short circuit power by the time duration power dissipation, static power by the various process of technology and dynamic power based on discharging and charging of load capacitance by equation 1. For power consumption reduction, of transistor switching is needed. Moreover, the whole system is improved by the gate functions and adder enhancement with the adder data path of the circuit.

$$\text{Dynamic Power} = \alpha (VDD)^2 f CL \quad (1)$$

$$P = f_c v_{dd}^2 + f_{short} v_{dd} + I_{leak} v_{dd} \quad (2)$$

Where, switching activities is denoted as α , supply of voltage as VDD, the load capacitances switching clock frequency as f_c and frequency as f . C denotes the per cycle of clock capacitance, α_n as activity factor of n node, node of voltage swing as V_{swing} , leakage circuit as I_l and the static circuit as I_{isc} . By the less supply of volt-age the delay of the circuit is increased. How-ever, the consumption of CMOS digital circuit power is signifying as in equation 2 and the aver-age power dissipated as given below.

$$P_{total} = P_{dynamic} (P_d) + P_{static} + P_{short-circuit} \\ = V_{DD} \cdot f_{clk} \cdot \sum \{ V_{nswing} \cdot C_{nload} \cdot \alpha_n \} + V_{DD} \cdot \sum I_{isc} + V_{DD} \cdot I_l \quad (3)$$

The hybrid full adder topology input and output of sum and carry relationship is expressed and generating as below.

$$\text{Sum} = A \oplus B \oplus C \text{ and Carry} = AB + C(A \oplus B)$$

The proposed design circuit of hybrid full adder topology is based on dual rail pass transistor logic (DRPTL) with clock signal and inverter logic. The circuit flow and criteria for robustness is summarized in section wise. The related review of various adder circuit topologies is discussed in section II. In section III the proposed design circuit and its implementation is explained. In Section IV, the analysis of simulation results of proposed circuit improvement is shown. Finally, the proposed work concludes with future work in Section V.

2. Related Work

In this section, the application of circuit design and the performances of previous adder circuits are discussed. In real time application adder circuit is a major part in various logic circuits. Generally, in any application logic circuit is a

major part of adder circuit for parameter consumption to enhance of performances and addersing at chip level. In adder cells, arithmetic system block is performed with the influenced of multipliers performances and the style of logic circuit considered is Shannon based adders, Pass transistor logic, Cmos logic and Transmission gates [2].

The basis analysis of performances is based on the less propagation delay, less area, efficient power delay product (PDP) and low power [3, 4]. Therefore, the design of the logic circuit is built based on required performances and compared to various circuits for analysis of performances. The hybrid CMOS design achieves better performances than the existing by providing less delay, power, area, good drivability, noise robustness, PDP and energy [7,8, 9]. The circuit of Hybrid-CMOS Full Adder is shown in Fig 1.

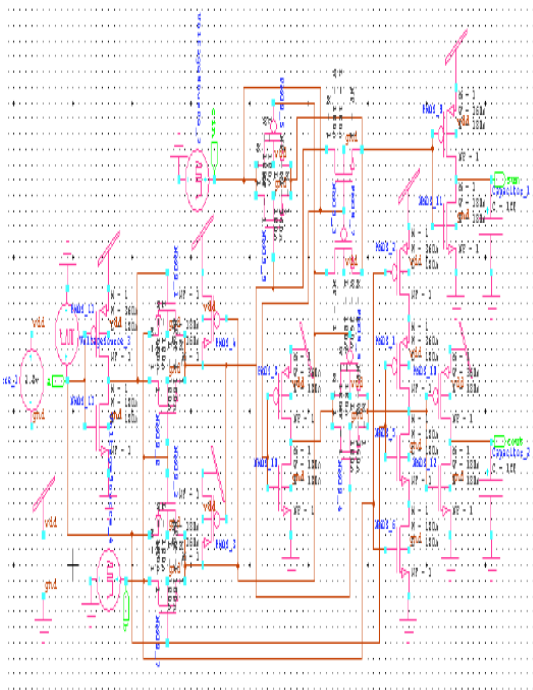

Fig.1: Hybrid-CMOS Full Adder

The system circuit internal components provide an efficient process with low power and high speed. The essential components are used to design the sophisticated hardware circuits and multiplexer is performed based the topology of pass transistor full adder with less area and transistor count [8].

As well as the CMOS adder circuit is designed based on Tanner EDA using T-SPICE and define the design of the gate 3T-XOR with its significant process [1]. The performances of the arithmetic and logic circuit of adder are illus-

trated the system performances as per the gate function. In digital systems, if adder lies on the critical path, then the delay of the overall system will increase [6, 13].

By using PTL-GDI technique in logic gate the transistor count is reduced in the adder circuit design and reduces the power, delay and area [5]. So, the upcoming adder circuit is designed based this technique for reducing the count of the transistor. In circuit implementation, the function of sum and carry is carried out by Pass transistor logic and Gate Diffusion Technique (GDI) respectively. Both functions separate the count of transistor equally [9, 10]. The methodology for power consumption and high speed is implemented in the ALU circuit of the 1-Bit XOR-XNOR full-adder circuits and illustrates the performances and compare results with the existing adder circuits show the proposed circuit best process with the faster efficiency and power [7, 12].

In various CMOS logic styles, the 1-bit full adder performed with the power dissipation and speed. The circuit is redesigned according to the logic style and the requirement of the transistor. For simulation Mentor Graphics ELDO simulations are used to evaluate the performances of the hybrid adder circuit [11].

Generally, PTL is used for the power consumption and the circuit is defined as LEAP (Also Single-Rail Pass-Transistor Logic). The consumption is based on the reduction of Switching activity, each node capacitance, short circuit current and voltage supply. The design of PTL is shown in Fig 2.

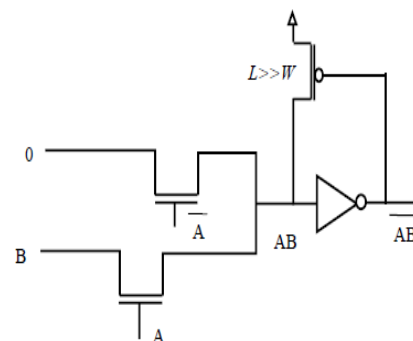

Fig.2: Design of PTL

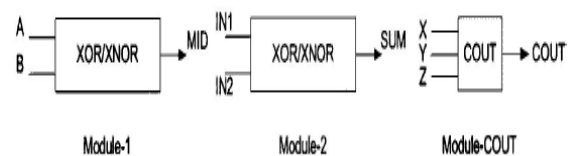

Fig.3: Hybrid Full Adder Modules

The hybrid CMOS full adder is considering into three modules. In module I, contain both the XOR and XNOR circuit else contain either one circuit. In module II contain the passing of intermediate signals and module III consists of generating the functions of the sum and carry output. As shown in Fig 3 the modules are performed. In this paper for better performances the Hybrid Full Adder Topologies is designed based on dual rail PTL with clock signal instead of Single Rail PTL.

3. Proposed Work

In this section, the proposed hybrid topology of full adder circuit is designed and implemented with dual or double rail pass transistor logic (DRPTL). A hybrid adder is modified with the proposed techniques to improve the performances of the system in terms of power, delay, PDP, transistor, EDP, leakage current and PEP. In proposed system, the proposed technique is implemented in modified hybrid full adder topology, so that the circuit is become a low power application in VLSI. By the modification of single pass in to dual pass the performances are varied and show better performances than the existing. Also, it provides low consumption of power and less size of logic operation in VLSI design. The basic function of sum and carry is performed in the arithmetic operations with the reduction of chip power and area.

As per the adder function implementation with transistor the SUM and CARRY function is carried out. The state of the transistor will be varied on or off according to logic 0 and logic 1. Also, if logic is low, then the input of logic 1 else the logic is high by the logic input 0. According to this function the power dissipation is evaluated and it is higher in sum function than the function of carry. As like existing adder circuit the proposed circuit is implemented, but proposed circuit is the implementation of design circuit with DRPTL and clock signal in hybrid topology of full adder.

Proposed Hybrid Full Adder Topology - Sum Function: The proposed structure is implemented based on inverter logic, dual or double rail pass transistor logic and parallel process with a clock signal to manage the circuit process. According to the style of logic the circuit is built with low consumption of power. Also, it generates with the hybrid function of logic gates.

Proposed Hybrid Full Adder Topologies - Carry Function: The logic function determining only odd numbers and the output of logic will be

equal to 1 only if the logic “1” input is higher than logic “0”. As per the clock function of signal the power management is performed on the circuit with the less transistor count, delay, area, and power; also with more robust, faster and reliable.

$$\text{Sum} = A \oplus B \oplus C;$$

$$\text{Carry} = AB + C(A \oplus B);$$

In topology circuit, the complementary CMOS transistor is processed and obtained the results with voltage swings. For low power and complexity, the proposed dynamic circuit is performed with fewer transistors and parallel function of dual transistor. Fig 4 shows the dynamic logic implementation. The difference of single and dual rail system is shown in Fig 5. In existing single rail signal system is implemented as a static logic design, but in the proposed circuit the design is implemented with the clock signal, Dual rail system, less transistor and dynamic logic. In dual system, the process of signal and the logic is consisting at a same time in the circuit. In proposed circuit, as per the pass gate function the circuit is designed and implemented with dynamic access.

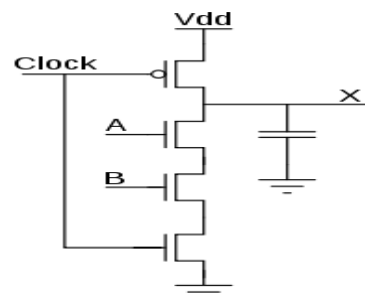

Fig.4: Dynamic Logic Implementation

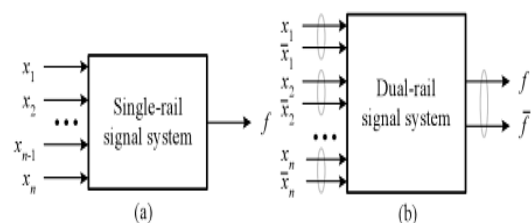

Fig.5: (a) Single Rail Signal System, (b) Dual Rail Signal System

Proposed Dual Rail Pass Transistor Logic (DRPTL): In this logic, Pass-Transistor is processed with the design of low power circuit. In pass network transistor is generated according to its function and perform sum and carry function as per the signal of a clock. At the end of generating voltage swing of the logic is performed. This logic provides improvement in speed, eliminating short circuit current in the output of inverter and includes voltage level restoration.

The DRPTL logic leads to have an efficient implementation with a clock signal for efficient dynamic access. It provides fast process and dynamic synthesis of logic functions in transistor network. Fig 6 shows the schematic diagram of the proposed hybrid circuit.



Fig.6: Proposed Schematic Diagram – Hybrid Circuit based on Improved DRPTL

The proposed logic improves the dynamic circuit speed with the evaluation of clock signal logic with transistor. The supply of voltage is varied based on the charges phases. If the clock signal is equal to 1 in the evaluation phase, then the circuit will be discharged or pre-charge and if equal to 0 in pre-charge phase, then the circuit is charged and applies to voltage supply level from the transistor. This dynamic logic is used to evaluate the power dissipation with the switching of transistor gate to the voltage supply. The block diagram of the proposed Hybrid full adder topology based on proposed improved DRPTL logic is shown in Fig 7.

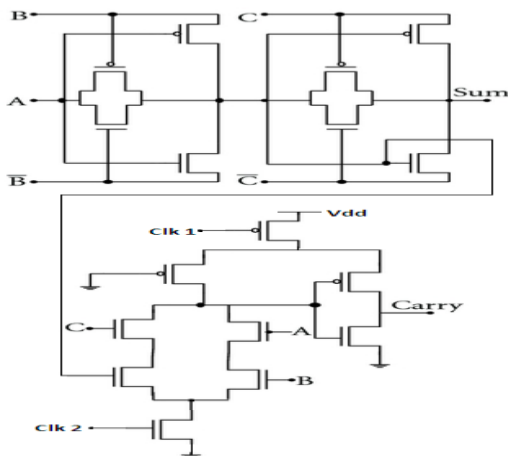

Fig.7: Proposed – Hybrid Full Adder Topology

4. Simulation Results

In this section, the proposed circuit simulation results are analyzed and shown the improved circuit efficiency than the existing circuit. From the range of voltage supply 0.6V to 1.8V the simulation is done for the comparison of design parameters with the existing full adder topology circuits. As well as the circuit is simulated at room temperature and the performances are analyzed by implementing the proposed circuit using 45nm CMOS technology on Cadence environment.

In the proposed system, due to less transistor usage only less area is required and the performances of the overall system are average at low supply of voltage. Below 1.1V the proposed design circuit is simulated and occupies the least silicon chip area. The schematic Cadence Virtuoso XL is used for design function of the layout. Fig 8 shows the test bench for simulation.

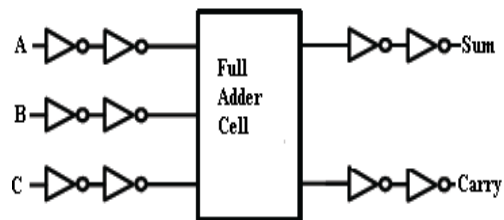

Fig.8: Simulation Test Bench

The logic output, circuit delay, and the inverter power are estimated in the simulation process. It determines the full adder capacitance parasitic implies. In layout design of proposed circuit is considered with the improvement of system performances and provides more efficient, less area occupies and reliable process than the existing circuit in VLSI circuit by a layout design. By compact design the area reduction is possible and the layout of the proposed circuit is shown with its logic functions. The design style of the proposed circuit is implemented in the programming environment based on Verilog HDL and the circuit is tested on Cadence tool.

The implementation of the proposed gate circuit is performed well with high redundancy. In VLSI, the proposed system optimizes the enhanced design to utilize the sub blocks in large circuit. The proposed logic design provides less count of transistor, less delay and less power dissipation. For efficient implementation of large VLSI system the proposed circuit is extremely enviable. The proposed design circuit layout is simulated using 45nm CMOS technology. The functional layout of sum and carry is shown in Fig 9 and Fig 10.

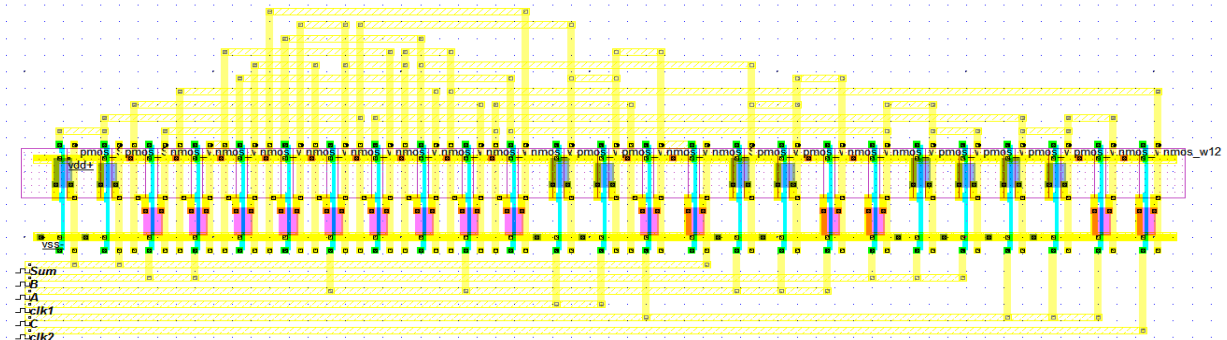

Fig.9: Proposed Hybrid Full Adder Topology - Sum Function

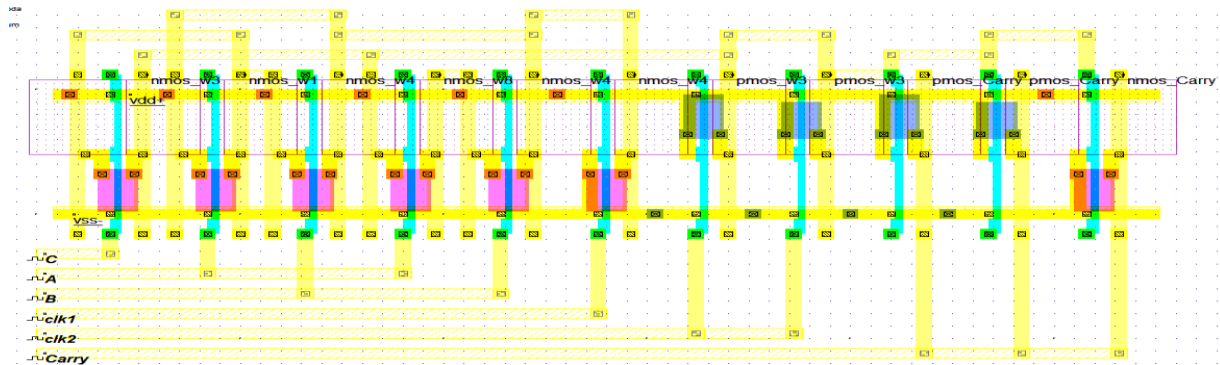

Fig.10: Proposed – Hybrid Full Adder Topology – Carry Function

Table 1: Comparison of Logic Circuit

Parameters	XOR-XOR	XNOR-XNOR	Centralized	SRPTL	Improved DRPTL
No. Transistors	24	24	24	19	17
Power	0.588mW	0.788uW	84.257uW	3nW	2.5nW
Delay	3000ps	3000ps	3000ps	2000ps	1500ps
PDP(Power Delay Product)(Femto/sec)	1.764	2.364	2.537	6E-3	5E-4
EDP(Energy Delay Product) (Femto/sec)	5.21E-6	7.092E-9	7.611E-7	12E-11	10E-13
Leakage Current	1.525mA	1.498mA	0.486mA	0.001mA	0.85 nA
PEP(Power Energy Product) (Femto/Sec)	6.098	1.812	2.137	5.4E-5	4.3e-5

Proposed Circuit - Hybrid Full Adder Topologies based Improved DRPTL

As per the results of simulation at every stage of path critical of the circuit the performances are analyzed and optimized the proposed circuits. During the process, the logic may degrade to “1” because of the threshold voltage drop else preventing the transistor inverter to ON tuning. Table 1 illustrates the performance comparison of various existing circuits with proposed circuit. The comparison parameters are EDP, Power, Delay, PDP, Transistor Count, PEP and Leakage current. As per the logic process the performance analysis is maintained and considered with less voltage operation.

The sub-threshold voltage leakage is becoming a rigorous control against to low power consumption. But compare to existing leakage in the proposed circuit reduce the leakage level and provides better and efficient power consumption. Also, it improves the speed and maintains the flow dynamically.

The simulation results of proposed circuit are considered with the logical function of sum and carry. According the circuit simulation the function of a Sum and Carry is carried out as shown in Fig 11 and Fig 12 respectively.

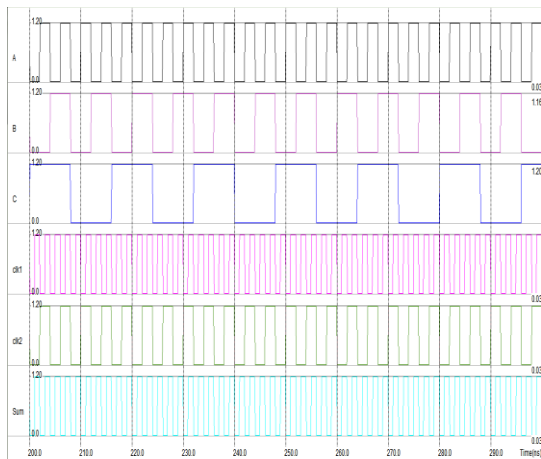

Fig.11: Simulation of Proposed Circuit - Sum Function

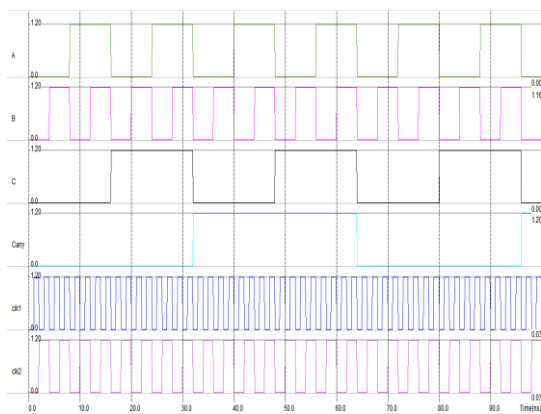

Fig.12: Simulation of Proposed Circuit - Carry Function

DRPTL the performances are evaluated by simulating the circuit at room temperature in 45 nm CMOS process technology. Finally, the proposed circuit shows more efficient and better performances with its improvement over the existing circuit.

Future work, the logic design simulation is needed to explore with low voltage supply for deep submicron technologies. In addition, with complete well-matched the logic gates involvement should be implemented for less count of the transistor.

5. Conclusion and Future Work

An internal logic circuit is proposed with the proposed approach to design and implement the circuit for efficient performances and analysis than the existing circuit. The proposed approach of the hybrid circuit provides faster process, less delay propagation, less power consumption and reduction in transistor count than the others. The proposed circuit performed with the logic improvement of dual and parallel process with clock signal in the proposed circuit. By the proposed style of hybrid CMOS with improved design.

REFERENCES

- [1] Jyotshna Kamath. B, Neetu Bani, Power Efficient CMOS Full Adders with Reduced Transistor Count. *International Journal of Engineering Research & Technology* 3(3): – (2014).
- [2] Laya Surendran E.K., Rony Antony P., Comparative Study of Adder Cells Using Different Logic Styles. *International Journal of Advanced Research in Computer and Communication Engineering* 3(8): (2014).
- [3] Manisha, Archana, A comparative study of full adder using static cmos logic style. *International Journal of Research in Engineering and Technology* 3(6): (2014).
- [4] Mathan, N. and A. Srimathi, Performance Evaluation of Low Power Adder in 32nm CMOS Technology. *International Journal of Advanced Science, Engineering and Technology* 3(3): 53-57 (2014).
- [5] V. Vinaykumar, V.Viswanadha, Design and Simulation of High Speed CMOS Full Adder. *International Journal of Engineering Trends and Technology* 15(4): (2014).
- [6] M. Geetha Priya, K.Baskaran, Low Power Full Adder With Reduced Transistor Count. *International Journal of Engineering Trends and Technology* 4(5): (2013)
- [7] Sushil B. Bhaisare, Sonalee P. Suryawanshi, Sagar P. Soitkar, Design of Low Power One-Bit Hybrid-CMOS Full Adder Cells. *International Journal of Engineering Trends and Technology* 4(5): (2013)
- [8] B. Dilli kumar, K. Charan kumar, M. Bharathi, Low power multiplexer based full adder using pass transistor logic. *International Journal of Advanced Research in Computer Engineering & Technology* 1(5): (2012).
- [9] Mohammad Shamim Imtiaz, Md Abdul Aziz Suzon, Mahmudur Rahman, Design of energy-efficient full adder using hybrid-cmos logic style. *International Journal of Advances in Engineering & Technology* (2012).
- [10] Rajkumar Sarma, Veerati Raju, design and performance analysis of hybrid adders for high speed arithmetic circuit. *International Journal of VLSI design & Communication Systems (VLSICS)* 3(3): (2012).
- [11] Vivek Kumar, Vrinda Gupta, Rohit Maurya, A Study and Analysis of High Speed Adders in Power-Constrained Environment. *International Journal of Soft Computing and Engineering (IJSCE)* 2(3): (2012)

- [12] Subodh Wairya, Rajendra Kumar Nagaria and Sudarshan Tiwari, New Design Methodologies for High Speed Low-Voltage 1-Bit CMOS Full Adder Circuits. *Computer Technology and Application* 2: 190-198 (2011)
- [13] Shubhajit Roy Chowdhury, Aritra Banerjee, Aniruddha Roy, Hiranmay Saha, A high Speed 8 Transistor Full Adder Design using Novel 3 Transistor XOR Gates. *International Journal of Electrical and Computer Engineering* 3: 784-790 (2008)