

SIMULATION OF SOLAR BASED POWER CONTROL FOR HEART PUMPING APPLICATION

HariPriya K,

Electrical & Electronics Engineering, Dr.N.G.P. Institute of Technology, Affiliated to Anna University, Chennai
 Coimbatore, India, Emails: harigayu22@gmail.com; mgopinath_10@yahoo.co.in

ABSTRACT

Solar PV system plays a vital role in renewable energy sources, which is applied for all fields of science and engineering. In this paper, the usage of solar energy for heart pumping application is discussed. Transcutaneous energy transfer (TET) is used for providing supply to implantable device with split capacitor push pull parallel resonant converter in boost mode operation. In existing system heart pumping is done via percutaneous cable. It has the drawbacks of infections and it's associated with risk. Transcutaneous energy transfer method eliminates these problems and it reaches the end to end efficiency level. The proposed system is configured using MATLAB/Simulink tools.

Index Terms- solar power, biomedical electronics, implantable devices, resonant converter, transcutaneous energy transfer coil (TET).

I. INTRODUCTION

Electrical energy is required for operation of implantable biomedical device such as artificial heart pumping. Solar energy is used to supplying for its operation. Percutaneous cables are used in early days to power the implantable device for regulating power flow. This method of power flow causes skin infection, in some cases can bleed out. To overcome these problem transcutaneous energy transfer (TET) systems plays an important role in offering the opportunity to provide wireless power transmission for implantable biomedical devices [3]. TET coil is capable of power delivering between two isolated coil when on coil is inside the body and other one is outside. Electromagnetic induction principle is used to transferring power across the skin for power regulating to the pumping device. In fig.1 shows that the block diagram of solar energy based heart pumping system with SC-PPRC. To generate the time varying magnetic field, high frequency AC current is made to flow through primary converter in external coil. In internal coil voltage is induced, which can be converted into power to drive the load.

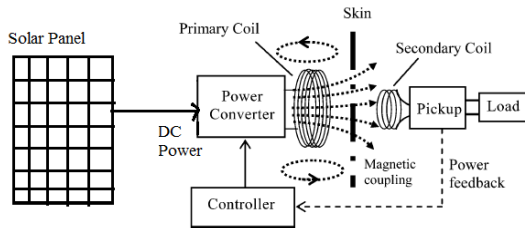

Fig.1. Heart Pumping System with Solar Energy

A split capacitor push pull parallel resonant converter (SC-PPRC) has been used in boost mode of operation. To achieve zero voltage switching condition split capacitor push pull resonant converter (SC-

PPRC) changes its operating frequency level and duty cycle simultaneously, by changing the primary switching frequency level directly, converter can regulate the power flow. In resonant technology allows the converter switches to be operated either with zero voltage or zero current or both zero current and zero voltage condition [7]. Switching and capacitive losses are very low compared to the other topology. They can operate most efficiently at an elevated frequency level to facilitate a compact design.

II. PHOTOVOLTAIC MODULE

P-N junction fabricated in a thin wafer of semiconductor is called solar cell. In solar energy the electromagnetic radiation can be converted into electricity through photovoltaic effect. Photon with energy greater than the band-gap energy of semiconductor creates some electron-hole pairs proportional to the incident irradiation when the sunlight is exposed to the panel [11].

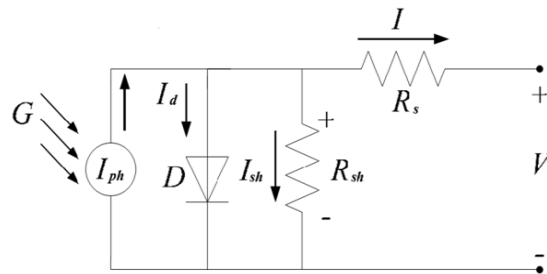

Figure.2. Equivalent Circuit of PV Cell

I_{ph} current source represents the cell photocurrent. The intrinsic shunt and series resistances are R_{sh} & R_s . The value of R_{sh} is very large and value of R_s is very small, to simplify the analysis R_s may be neglected. To form PV modules, PV cells are grouped in

larger units. Solar electric system converts sunlight to DC electricity, the same type of electricity that is produced by every day batteries where electrons flow in one direction. Solar cells, generally consists of two layers of silicon(semiconductor material) and a separation layer, are wired together and assembled into panels or modules.

III. TRANCUTANEOUS ENERGY TRANSFER

A). SYSTEM OVERVIEW

Delivering power to the high power implantable devices with the TET system shown in Fig.3.

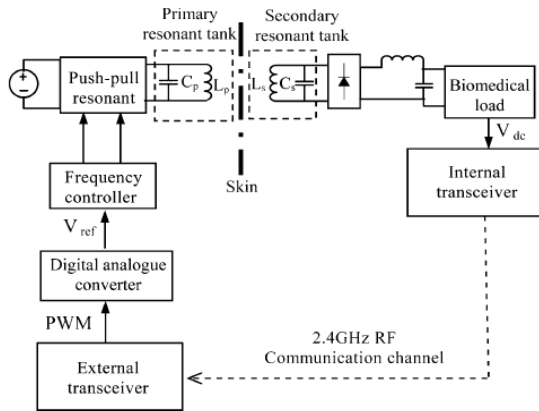

Figure.3.TET System Architecture.

It consists of a split capacitor push pull parallel resonant converter and pickup parallel tuned resonant with a resistive AC load. Adding a rectification circuit before the load provides power for an implanted medical device and internal rechargeable battery.

B). TET COILS

TET coils used in this paper were designed with thin and compact to maintaining good level of coupling with a wide displacement tolerance. TET coils are encapsulated in biocompatible grade silicon MED-4011 material; it is suitable for implantation.

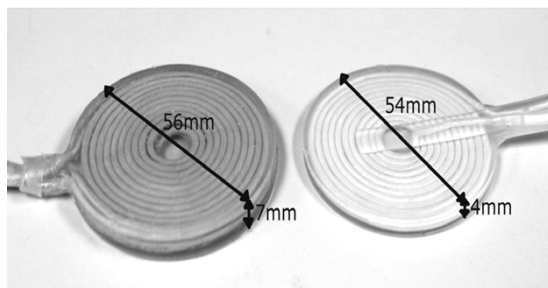

Figure.4. TET coils

TET coils have 56mm and 54mm diameter, thickness of 7mm and 4mm for primary and secondary coils, respectively [10]. Coils were wound

with 1.8mm*1.8mm square litz wire consisting of strands with 0.071mm diameter, made up of 22&11 turns, respectively.

C) OPERATING FREQUENCY

In TET system, for efficient operation soft switching technique such as zero current and zero voltage switching methods are used. TET system includes Four reactive components are L_1, L_2, C_1, C_2 resonant inductance and resonant capacitance of primary and secondary coils respectively. When coil separation is large the natural frequency is governed by the impedance of $L_1 & C_1$ as the effect of the secondary reflected impedance is negligible, when the coil separations is small the reflected secondary impedance affects primary impedance, so the natural resonant frequency can be changed.

D) PI CONTROLLER

V_{load} is equal to the V_{ref} at the time PI controller achieves regulation, in order to achieve regulation V_{IN} should be chosen in such a way that the frequency controller has a margin to vary the power flow up or down. To determine the f_{sw} regulation range then the system has to operate under closed loop condition. PI action starts to regulate V_{load} to V_{ref} by decreasing the frequency downwards to increasing the V_{IN} value. When f_{sw} equates to the desired lower boundary of the f_{sw} regulation range, V_{INstop} to increasing. This process ensures that the system is capable of regulating voltage down to V_{ref} in highest coupling level. When the coupling level is decreased by distance of coil separation, PI system will increase f_{sw} to deliver more sufficient power to maintain V_{ref} value at the load level.

IV. SIMULATION AND RESULTS

A) SOLAR PANEL DESIGN

Solar panel design for the system is simulated by using MATLAB/Simulink tool with a temperature range of (30+273.15). The simulation model for solar panel design and sub system model is shown in Fig. 5 & 6 respectively. The output parameters such as voltage, current, power are shown in Fig. 7.

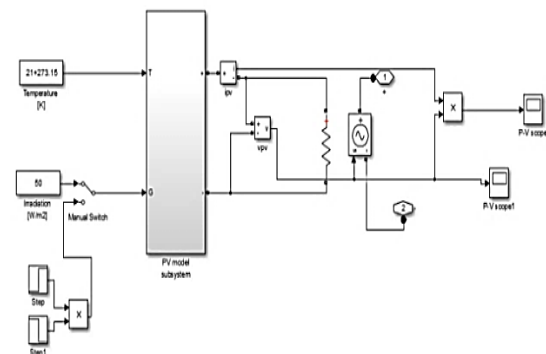

Figure.5.Solar Panel Simulink Model

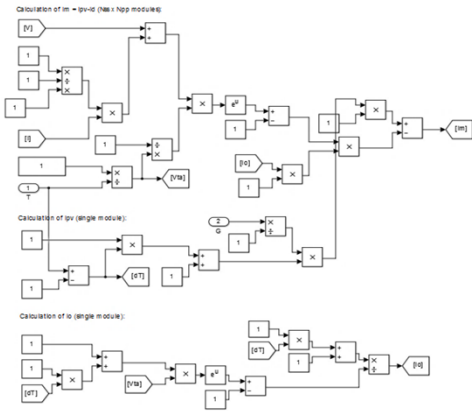

Figure.6. Sub System Model

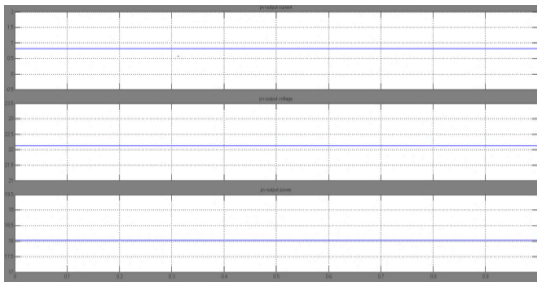

Figure.7.Simulation Results of Solar Panel Design

B).SIMULINK MODEL FOR CLOSED LOOP SOLAR POWER FED HEART PUMPING SYSTEM

Implantable biomedical device such as artificial heart pumping system has required continuous power flow for regulating the device. It has been done by using PI controller action. Normal pumping device is required in the power range of 10W for a load of 10Ω.

Simulation results taken for the closed loop system, V_{IN} is set in the range of 22V to 25V for the load of 10Ω. Simulink model for closed loop system is shown in Fig.8 and the output results such as current, voltage & power for the system demonstrated in Fig. 9.

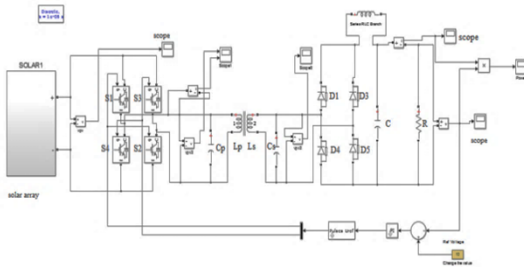

Figure.8.Closed Loop System Model

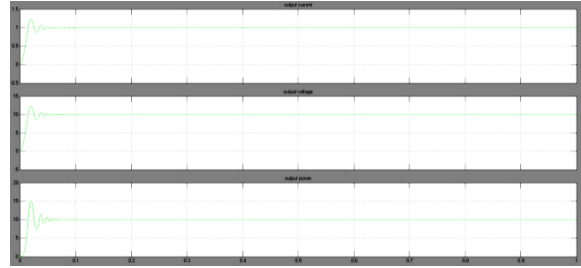

Figure.9. Output Results of Closed Loop Model

V. CONCLUSION

In this paper, Simulation of solar based power control for heart pumping application is done by using split capacitor push pull parallel resonant converter with PI controller action for regulating the power flow. By employing transcutaneous energy transfer coil(TET) for power transfer between the skin, it reduces the infection and provides good power flow regulation with a closed loop control. It also increases the end to end efficiency level.

VI. REFERENCES

- [1] Bidyadhar Subudhi and Raseswari Pradhan, A Comparative Study on Maximum Power Point Tracking Techniques for Photovoltaic Power Systems. IEEE Transaction on Sustainable Energy **4**(1):89-98 (2013).
- [2] Bo-Yuan Chen and Yen-Shin Lai, New Digital-Controlled Technique for Battery Charger with Constant Current and Voltage Control without Current Feedback. IEEE Transaction on Industrial Electronics **59**(3): 1545-1553 (2013).
- [3] Bob Wang, Aiguo Patrick Hu and David Budget, Power Flow Control Based Solely On Slow Feedback Loop for Heart Pump Applications. IEEE Transaction on Biomedical Circuits and Systems **6**(3):279-286 (2012).
- [4] Chwei-Sen Wang, Grant A. Covic and Oskar H. Stielau, Power Transfer Capability and Bifurcation Phenomena of Loosely Coupled Inductive Power Transfer Systems. IEEE Transaction on Industrial Electronics **51**(1): 148-157 (2009).
- [5] Chao Liu and Aiguo Patrick Hu, Steady State Analysis of a Capacitively Coupled Contactless Power Transfer System. IEEE Transaction on Industrial Electronics **53**(6): 3233-3238(2009).
- [6] Dissanayake. T., D. Budget, A. P.Hu and S. Malpas, Transcutaneous Energy Transfer System for Powering Implantable Biomedical Devices. Chwee Teck Lim, James C.H. Goh (Eds.): ICBME 2008, Proceedings **23**: 235-239 (2009)
- [7] Duleepa J. Thrimawithana and Udaya K. Madawala, Analysis of Split Capacitor Push Pull Parallel Resonant Converter in Boost Mode. IEEE Transaction on Power Electronics **23**(1): 259-268 (2008).
- [8] Thrimawithana, D.J., U.K. Madawala and P. Lunenburg, A Novel Buck-Boost Control Technique for Push Pull Parallel-Resonant Converters. IEEE Transaction on Power Electronics **13**(5): 2805-2811(2006).

- [9] Ho Yan Leung, David M. Budget and Aiguo Patrick Hu, Minimizing Power Loss in Air-Cored Coils for TET Heart Pump Systems. *IEEE Journal on Emerging Topics in Circuits and Systems* **1**(3): 412-419(2011).
- [10] Jimei Ma, Qingxin Yang and Haiyan Chen, Transcutaneous Energy and Information Transmission System with Optimized Transformer Parameters for the Artificial Heart. *IEEE Transaction on Applied Superconductivity* **20**(3): 798-801 (2010).
- [11] Jay Patel and Gaurag Sharma, Modeling and Simulation of Solar Photovoltaic Module Using Matlab/Simulink, *International Journal of Research in Engineering and Technology* **2**(3): 225 (2013).
- [12] Liangyu Bai, Houjun Tang and Yang Xu, Optimization Model of the Transcutaneous Energy Transmission System for Achieving Maximum Power Transfer Capability. *Journal of Computer* **6**(2): 305-312 (2011).
- [13] Leung H.Y., D.M. Budgett, D.McCormick and A.P. Hu, Wireless Power system for Implantable Heart Pumps Based on Energy Injection Control. *Progress in Electromagnetics Research Symposium Proceeding*, Pp-445 (2012).
- [14] Ping Si, Aiguo Patrick Hu, Simonn Malpas and David Budget, A Frequency Control Method for Regulation wireless power to Implantable Devices. *IEEE Transaction on Applied Superconductivity* **2**(1): (2008).
- [15] Pandiarajan N. and Ranganath Muthu, Mathematical Modeling of Photovoltaic Module with Simulink. *International Conferences on Electrical Energy Systems* **3**(5): 314-319(2011).